

PERFECT POWER SPRAYER

User Guide and Parts List

nox-crete®

chemical solutions to [concrete](#) problems

Model:

PPS-P - Pail Version

PPS-D - Drum Version

PPS-T - Tote Version



* Batteries not included

Nox-Crete Inc.

1444 S. 20th St., PO Box 8102 Omaha, NE 68108 USA

Office: 402-341-2080 | 800-669-2738 | Fax: 402-341-9752

customerservice@nox-crete.com | www.nox-crete.com

INTRODUCTION

You have purchased a quality Nox-Crete sprayer, proudly made in the USA. If you use and maintain your sprayer properly, you will enjoy many years of safe, reliable service.

The Nox-Crete Perfect Power Sprayer utilizes a magnetically coupled gear pump and 1 DeWalt® Lithium Ion 20V, 4Ah or greater battery. Also works with DeWalt Flexvolt 20Volt / 60 volt, 6,9 or 12Ah batteries.

TABLE OF CONTENTS

Safety Information	2,3
Warranty	4
Proof of Purchase	5
Specifications	5
Operation	5
Contents of Carton	5
Assembly	6
Sprayer Startup	7
Clean Up	8
Chemical Compatibility	8
Troubleshooting	9
Maintenance	10
Service	10
Replacement Parts	10
Spray Tip Chart	10
PPS Shut-Off, Wand Assembly and Intake Line Parts List	11,12
PPS and Output Line Parts List	13,14
Recommended Cleaning Products	15,16

SAFETY INFORMATION

INTRODUCTION

This Safety Alert Symbol is used to call attention to items or operations which may be dangerous to those operating or working with this sprayer. The symbol can be found throughout this manual. Please read these warnings and cautions carefully before attempting to operate the unit. Make sure every individual who operates or works with this sprayer is familiar with all safety precautions.

▲ WARNING ▲

GENERAL WARNING: Indicates information important to the proper operation of the sprayer. Failure to observe may result in damage to the sprayer and/ or severe bodily injury or death.

▲ CAUTION ▲

GENERAL CAUTION: Indicates information important to the proper operation of the equipment. Failure to observe may result in damage to the equipment.

REFERENCES: For details on safety rules and regulations in the United States, contact your local Occupational Safety and Health Administration (OSHA) office. Equipment operated in other countries must be operated and serviced in accordance and compliance with any and all safety requirements of that country. The publication of these safety precautions is done for your information. Nox-Crete does not by the publication of these precautions imply or in any way represent that these are the sum of all dangers present near Nox-Crete equipment. If you are operating Nox-Crete equipment, it is your responsibility to insure that such operation is in full accordance with all applicable safety requirements and codes. All requirements of the United States Federal Occupational Safety and Health Administration Act must be met when operated in areas that are under the jurisdiction of the United States Department.

▲ WARNING ▲

- ▲ Before attempting to operate the sprayer, read and understand all safety precautions and warnings.
- ▲ Do not use the sprayer when tired, ill, or under the influence of alcohol, drugs or medication.
- ▲ Inspect sprayer before each use for loose, broken, cracked, split, or damaged parts. Do not operate the sprayer with loose or damaged component parts.

- ▲ Always wear safety glasses or goggles that are marked with ANSI Z87
- ▲ Use only in daylight or good artificial light.
- ▲ Never use sprayer without the proper factory authorized accessories attached. When using the sprayer, ensure that the sprayer discharge hose is securely attached.
- ▲ Do not modify the sprayer.

▲ CAUTION ▲

IT IS YOUR RESPONSIBILITY TO ENSURE THAT THE MATERIAL YOU ARE SPRAYING IS COMPATIBLE WITH THE SPRAYER.

▲ CAUTION ▲

- ▲ If the product being sprayed is intended to cure or set up after application, the Sprayer must be cleaned. Flush with cleaning solvent recommended for specific Nox-Crete product for 60 seconds or more. Leave cleaning solvent in pump until next use. If cleaning solvent is water protect pump from freezing or replace water with RV antifreeze. Failure to clean the unit after using these types of materials will result in failure of the unit and loss of warranty coverage.
- ▲ Do not use abrasives
- ▲ Never use without Intake Filter
- ▲ Attempting to spray Nox-Crete products below Nox-Crete's recommended temperatures may affect the sprayers ability to adequately perform. Low temperatures may affect product viscosity.
- ▲ Do not submerge or expose to excessive moisture
- ▲ Do not spray products with solids above 25% or with abrasive additives as this will destroy the pumps gears and will void the warranty. This Sprayer is intended for use with specific Nox-Crete products. If you are unsure of the suitability of the product you want to spray contact Nox-Crete at 402-341-2080 for assistance.

WARRANTY

▲ CAUTION ▲

▲ DO NOT ATTEMPT TO SERVICE THE UNIT BY REMOVING THE COVER. REMOVAL OF THE UNIT COVER WILL VOID THE WARRANTY. CONTACT NOX-CRETE FOR SERVICE INFORMATION

Nox-Crete warrants this product to be free from material or workmanship defects for a period of 60 days from the date of purchase.

Warranty does not apply when:

- Product is not used within the guidelines of this manual.
- Repairs are made outside of Nox-Crete authorized service center.
- Incompatible fluids are used.
- Misuse or Abuse.
- Improper or inadequate cleaning of unit after use.

In the event you need to utilize this warranty, the product or part must be returned for examination, postage prepaid, direct to the Nox-Crete service center as instructed by Nox-Crete. Proof of purchase date and an explanation of the claim must accompany the merchandise. If inspection discloses a defect, Nox-Crete will either repair or replace the product with like equipment at Nox-Crete's expense. If no defect is found during the inspection, or if the defect resulted from causes not within the scope of Nox-Crete's limited warranty, then the user must assume all costs incurred returning and/or storing the product.

All products and parts will be tested using Nox-Crete testing criteria. Units found to be damaged, altered or otherwise mistreated will not be covered under this warranty. Units found not to be defective are subject to charges to be paid by the returnee.

Nox-Crete shall in no event be liable for death, injuries to persons or property or for incidental, contingent, special or consequential damages of any kind by the reason of use or sale of any defective product or part. This limited warranty covers units distributed in the United States of America and Canada only.

This limited warranty is in lieu of all other warranties, expressed or implied, and no other person is authorized to give any other warranty or assume obligation or liability on behalf of Nox-Crete Inc.

Products and parts must be flushed free of all fluids prior to returning to Nox-Crete for warranty inspection.

PROOF OF PURCHASE

Please retain your dated sales receipt as proof of purchase to validate the warranty period.

SPECIFICATIONS

Pump	Magnetic drive gear pump with brushless motor
Pump Voltage	20-24 Volts
Approved batteries	DeWalt® 20V
Flow Rate	0.10 to 0.70 GPM
Battery Life	Varies depending on the Amp Hour (Ah) of battery selected
Pressure	Constant 70 PSI

OPERATION

▲ WARNING ▲

Carefully read through this entire manual before attempting to use your new product. Pay close attention to the safety alerts symbols, warnings and cautions.

CONTENTS OF CARTON

Contents of Carton include:

1. Cordless sprayer assembly
2. Spray gun
3. 18 Inch angled wand
4. 5 Ft. or 50 Ft. spray hose assembly
5. Intake line for 5 gallon pail or 55 gallon drum
6. 2 spray tips
7. Blue 50 mesh strainer
8. Plastic tip retainer cap
9. Operator's safety and service manual

Battery and battery charger not included.

Examine all parts to ensure that everything is accounted for and no damage has occurred during shipment.

ASSEMBLY

To prepare the unit for operation, assemble the sprayer as follows:

1. Spray tip & wand strainer
 - a. Attach one of two supplied spray tips and wand check valve/filter to end of wand
2. Assemble spray hose
 - a. Attach spray hose to the spray gun and sprayer unit. Both ends are the same.
3. Attach intake line
4. Position sprayer and intake tube over opening in 5 gallon pail or 55 gallon drum.
5. Set the sprayer unit on top of the container by guiding the inlet tube into the hole in top of container.
6. Set the power switch to the off position
7. Slide the battery into the receptacle, **DO NOT FORCE**. When properly aligned it will slide in easily. When fully inserted you will hear a click.
8. Check the sprayer trigger handle to make sure the lever is not locked in the open/on position.

SPRAYER STARTUP

Keeping all safety and operating measures in mind you are now ready to begin spraying.

4. Prime the Sprayer
 - a. Turn power switch to on position.
 - b. Squeeze the spray gun handle.
 - c. The pump is self priming and should begin spraying in a few seconds.
 - d. If the pump does not prime within 10-15 seconds it will shut down. Check to see that all fittings are tight and the intake filter is not clogged. Turn the pump off then back on or remove and replace battery to restart.
 - e. After liquid is flowing and all air is purged from the lines, release the handle and the sprayer will turn off.

The pump is designed for continuous duty when proper operating criteria are met.

▲ CAUTION ▲

BEFORE REMOVING THE SPRAY HOSE, TURN THE POWER OFF AND RELIEVE ANY PRESSURE IN THE SPRAY HOSE BY SQUEEZING THE SPRAY HANDLE.

CLEAN UP

▲ CAUTION ▲

As with any type of sprayer, this sprayer will not function satisfactorily if it is not kept clean. If the product being sprayed is intended to cure or harden after application, the Sprayer must be cleaned and flushed after EACH use. Flush sprayer with cleaning solvent specifically recommended for Nox-Crete product used in sprayer for 60 seconds or more (see recommended Nox-Crete cleaning product chart on page 17). Leave cleaning solvent in pump until next use.

Failure to clean the unit after using these types of materials will result in failure of the unit and loss of warranty coverage.

The sprayer is programmed to stop running 10-15 seconds after it runs out of material from the pail or drum.

DO NOT USE THE SPRAYER PUMP TO PURGE THE PICKUP TUBE OR DISCHARGE HOSE. Running the Pump dry will destroy the gears and void the warranty. Disconnect pick up tube and discharge hose on each end and drain manually.

CHEMICAL COMPATIBILITY

The magnetically coupled gear pump used in the sprayer has no seals or gaskets in the fluid path and therefore will not leak. The only surfaces in the pump that come in contact with the fluid being sprayed are stainless steel, ceramic and PEEK (polyetheretherketone). The gears in the pump are made out of PEEK and are resistant to all Nox-Crete products suitable for use with this sprayer.

SPRAYER WILL NOT START

- ✓ If battery is not properly seated and fully charged
- ✓ If On/Off switch is in the off position

SPRAYER WILL NOT PRIME

- ✓ If intake tube or discharge hose is restricted
- ✓ If spray tip or filter on end of wand is plugged
- ✓ If you are out of product
- ✓ If battery is not properly charged
- ✓ If there is a crack, split or other leak in suction tube

SPRAYER OUTPUT VOLUME REDUCED

- ✓ If pickup tube or discharge hose have restrictions such as dirty inlet or outlet filters
- ✓ If spray tip is dirty or partially plugged
- ✓ If viscosity of material being sprayed exceeds pumping capability of sprayer
- ✓ If material being sprayed is too cold

ALARM SOUNDS

- ✓ Sprayer pump ran dry for 15 seconds. Turn pump off and then on again, or remove and reinstall battery to terminate alarm and reset pump.

MAINTENANCE

No Routine Maintenance is required.

Thoroughly clean of the entire unit by flushing the internal components and wiping exterior surface with Nox-Crete recommended cleaning solvent for Nox-Crete product used in sprayer. See Nox-Crete product literature for specific cleaning solvent recommendations or page 15 & 16 of this manual.

SERVICE

▲ CAUTION ▲

Service on this unit both within and after the warranty period should be performed only by Nox-Crete or an authorized service center. For more information contact Nox-Crete customer service at 402-341-2080 or customer.service@nox-crete.com.

REPLACEMENT PARTS

For replaceable parts, please contact Nox-Crete customer service at 402-341-2080, or customer.service@nox-crete.com.

SPRAY TIP CHART

Spray Tip Size	Output in GPM at 70 PSI
8001	0.13
80015	0.20
8002	0.26
8003	0.40
8004	0.53
8005 (maximum tip size that can be used)	0.66

PPS Shut-Off, Wand Assembly and Intake Tube Parts List

Part #	Description
463	shut-off / wand adapter
8003 & 8005	standard spray tips. Alternative spray tip sizes available.
8442	plastic tip retainer cap
897	inlet adaptor
898	strainer housing
8464	18" stainless steel wand
8305	45 degree stainless steel elbow
8502	blue 50 mesh wand strainer
8604	all metal pistol grip shut-off
8606	drum/tote inlet strainer
8634	pail inlet strainer
8637	5 gallon pail intake line
8639	55 gallon drum intake line
PPSTPL	275 gallon tote intake line
PPSSWA	shut off / wand assembly
8659	PTFE flat gasket/washer
8672	brass hex swivel 1/4" female GHT
8673	pinch clamp

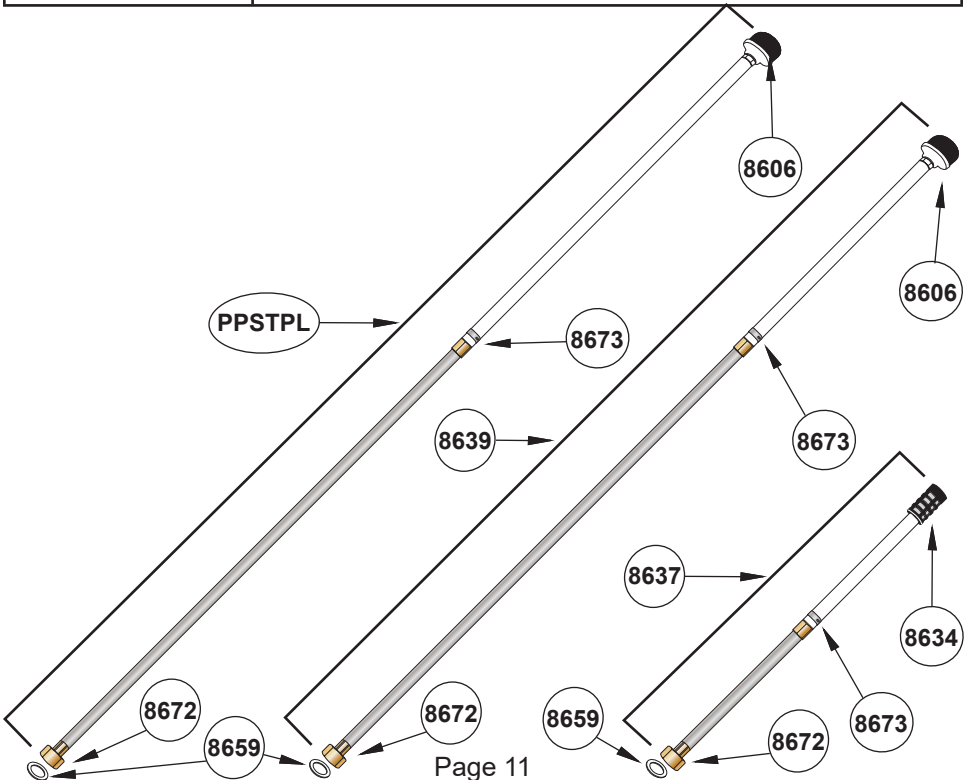

8604

463

897

8464

PPSSWA

8305

898

8502

8442

Standard spray tips - 8003, 8005
Available spray tips - 8001, 80015, 8002, 8004

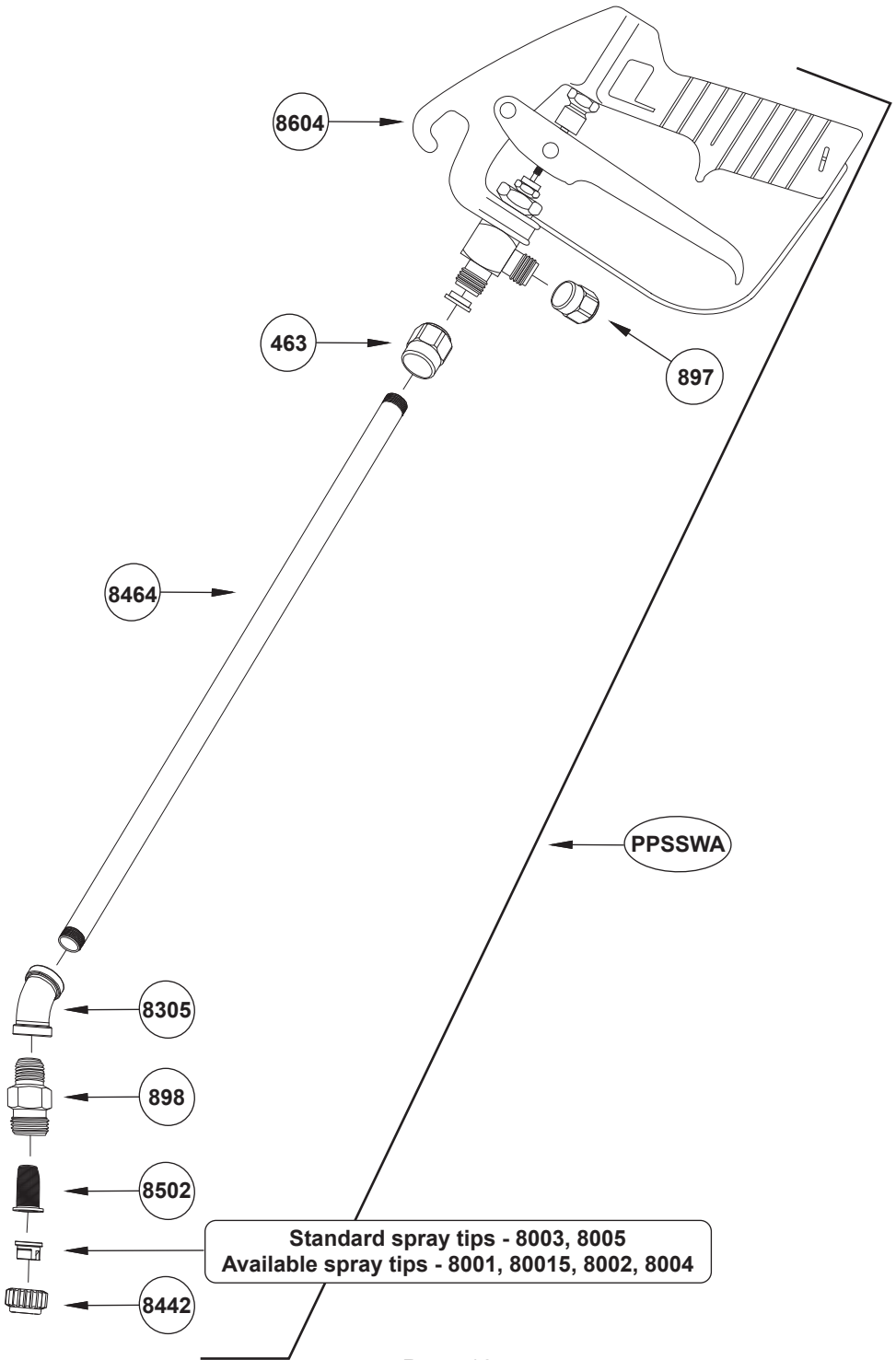

PPS and Spray Hose Parts List

Part #	Description
8641	5 feet of spray hose and connection fittings
8642	50 feet of spray hose and connection fittings

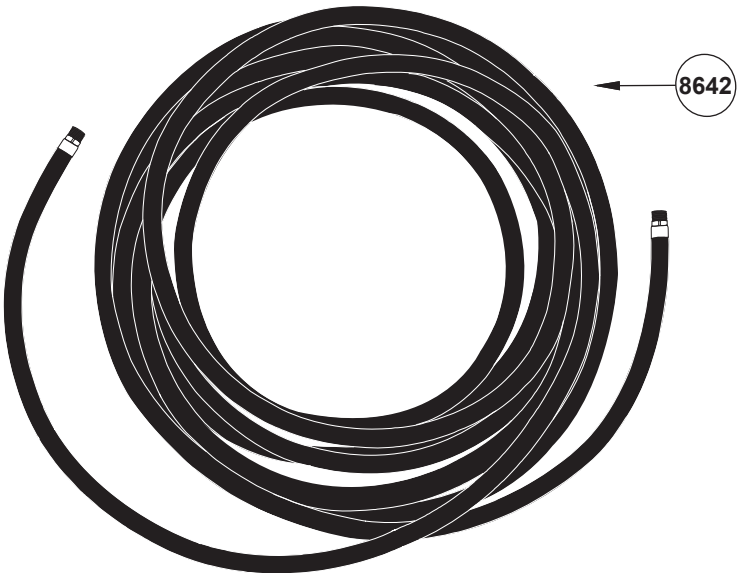
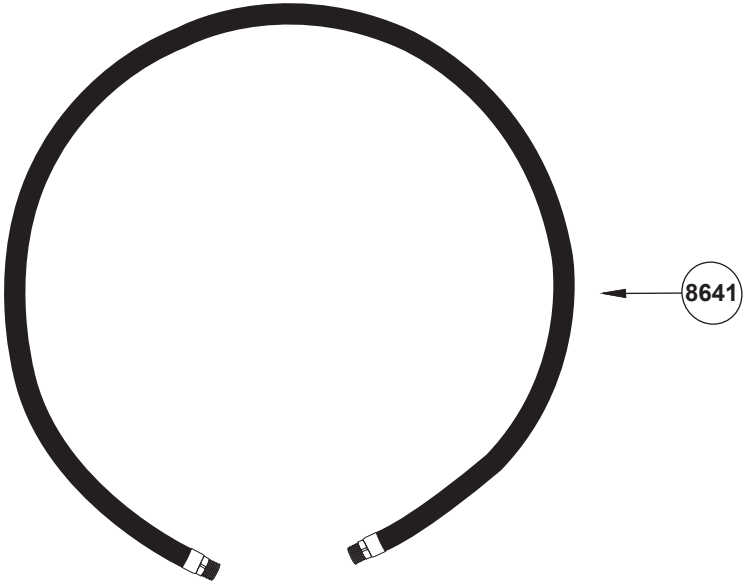

Perfect Power Sprayer
(excludes parts 8637, 8639, PPSSWA, 8641, 8642)

Part #	Description
PPS	Perfect Power Sprayer Pump and Housing

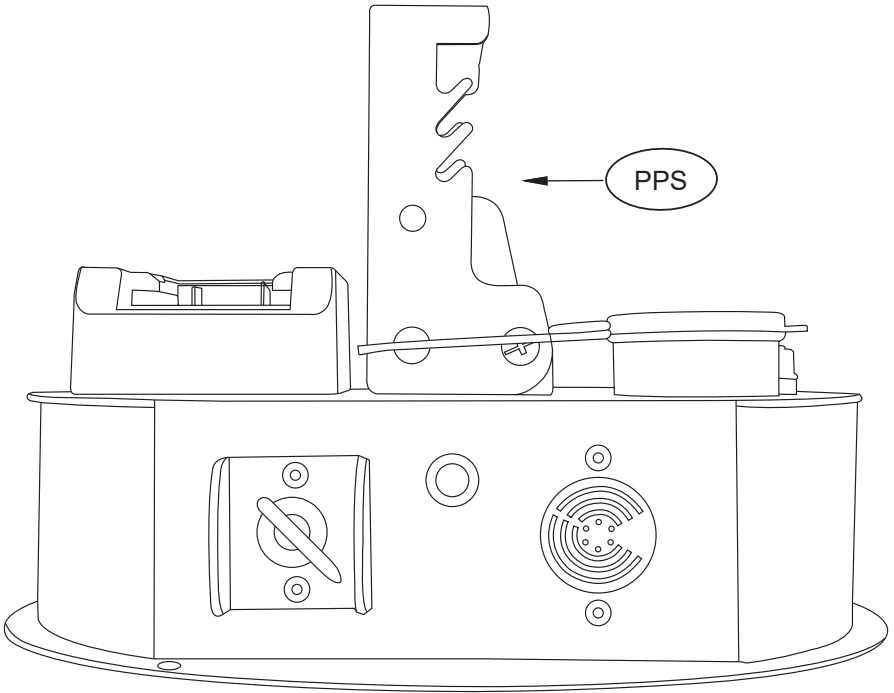

RECOMMENDED NOX-CRETE CLEANING PRODUCTS

DESCRIPTION	WATER	SOLVENT A	SOLVENT B	SOLVENT C	SOLVENT D	BIO-CLEAN PLUS	PRE-FORM SOLVENT	COMMENTS
ALUMI-CON	X	X						* Before proceeding, verify recommended cleaning solvent complies with local VOC regulations Use Solvent A to remove all residue
ALUMINOX R 250 (All Versions)		X						
BIO-NOX	X	X						Use Solvent A to remove all residue
BIO-NOX VS		X						
BRO-CURE READY TO USE	X							
CHEMBETON (All Versions)		X						
CLEAN RELEASE (All Versions)		X						
CLEAR-CURE DH 100	X	X						Use Solvent A to remove all residue
CRETE-NOX TA	X							
CURE & SEAL 1315A (All Versions)			X					
CURE & SEAL 150E	X		X					Use Solvent B to remove all residue
CURE & SEAL 250E	X		X					Use Solvent B to remove all residue
CURE AND SEAL 309 - 350			X		X			Local VOC regulations dictate which solvent to use
DEACTIVATOR		X						
DRYCAST RELEASE		X						
DRYCAST RELEASE HSS		X						
DURO-NOX	X							
DURO-NOX HS	X							
DURO-NOX HSC	X							
DURO-NOX LS	X							
DURO-NOX LSC	X							
DURO-POLISH	X		X					Use Solvent B to remove all residue
DURO-POLISH PLUS	X		X					Use Solvent B to remove all residue
DURO-SHIELD	X		X					Use Solvent B to remove all residue
FORM-ARMOR		X				X		Use Solvent A for application equipment cleanup and Bio-Clean Plus for removal of applied films
FORM-CLEAN (All Versions)		X						
FORM COATING 450		X						
FORM COATING E	X	X						Use Solvent A to remove all residue
FORM COATING 250		X						
FORM COATING 100		X						
HARBETON	X							
MONOFILM	X							

RECOMMENDED NOX-CRETE CLEANING PRODUCTS

DESCRIPTION		WATER	SOLVENT A	SOLVENT B	SOLVENT C	SOLVENT D	BIO-CLEAN PLUS	PRE-FORM SOLVENT	<p style="color: red; font-size: small;">* Before proceeding, verify recommended cleaning solvent complies with local VOC regulations</p> COMMENTS
NATRASEAL				X		X			Local VOC regulations dictate which solvent to use
PALLET-NOX 100	X								
PRECAST RELEASE #80 250			X						
PRECAST RELEASE #80 450			X						
PRECAST RELEASE #92			X						
PRECAST RELEASE #85			X						
PRECAST RELEASE EL			X						
PRO RELEASE 3.0	X	X							Use Solvent A to remove all residue
QUICK RELEASE			X						
RELEASE AGENT #10 100/250/450			X						
RELEASE AGENT #10E	X	X							Use Solvent A to remove all residue
RES-CURE DH 100	X	X							Use Solvent A to remove all residue
RES-CURE DS	X		X						Use Solvent B to remove all residue
SEASONOX EXT	X								
SILCOSEAL 2000 F	X	X							Use Solvent A to remove all residue
SILCOSEAL ADVANTAGE	X	X							Use Solvent A to remove all residue
SILCOSEAL ADVANTAGE LVOC	X	X							Use Solvent A to remove all residue
SILCOSEAL CLASSIC			X						
SILCOSEAL EX			X			X			Local VOC regulations dictate which solvent to use
SILCOSEAL SELECT	X	X							Use Solvent A to remove all residue
SPARKL-SEAL 700			X						
SPARKL-SEAL E	X		X						Use Solvent B to remove all residue
SPARKL SEAL 350			X						
STIFEL 40 - 600			X						
STIFEL 40 - 400			X			X			Local VOC regulations dictate which solvent to use
STIFEL GC	X	X							Use Solvent A to remove all residue
STIFEL SC	X	X							Use Solvent A to remove all residue
STIFEL VC	X	X							Use Solvent A to remove all residue
TRI-SHIELD 350			X			X			Local VOC regulations dictate which solvent to use
WEATHER-SIL	X	X							Use Solvent A to remove all residue
WEATHER-SIL EXTREME	X	X							Use Solvent A to remove all residue

Nox-Crete Inc.
1444 S. 20th St., PO Box 8102 Omaha, NE 68108 USA
Office: 402-341-2080 | 800-669-2738 | Fax: 402-341-9752
customerservice@nox-crete.com | www.nox-crete.com

