



USER MANUAL

Read And Follow All Instructions For Use

nox-crete[®]

chemical solutions to **concrete** problems

PERFECT POWER FOAMER

402-341-2080
customerservice@nox-crete.com

www.nox-crete.com

READ ALL INSTRUCTIONS BEFORE OPERATING EQUIPMENT



WARNING



Read this manual completely and understand the machine before operating or servicing it.

- Read all instructions before installing or operating unit.
- Always wear appropriate personal protective equipment (PPE) when operating or servicing unit.
- Always follow all chemical safety precautions and handling instructions provided by the chemical manufacturer and Safety Data Sheet (SDS).
- If this unit is modified or serviced with parts not listed in this manual, the unit may not operate correctly.
- Never point the discharge wand at yourself, another person, or any object you do not want covered in chemical.
- Always depressurize unit after use (as described in the After Use Instructions). Always store unit depressurized, with the discharge valve in the closed position.
- Do not exceed an incoming air pressure of 100 psi (7 bar).
- Do not exceed a fluid temperature of 100°F (37°C).
- Always flush the unit with fresh water for 2-4 minutes when switching from an alkaline to an acid or an acid to an alkaline.
- Only use clean and dry air. Air must be filtered and free of moisture or pump life will be diminished. If needed, install an air dryer before unit.
- Do not use an air lubricator before the unit.
- Never use unit with hydrocarbons or flammable products.

PROTECT THE ENVIRONMENT

Please dispose of packaging materials, old machine components, and hazardous fluids in an environmentally safe way according to local waste disposal regulations.



Always remember to recycle.

*Specifications and parts are subject to change without notice.

READ ALL INSTRUCTIONS BEFORE OPERATING EQUIPMENT

REQUIREMENTS	
Compressed air requirements	40-80 psi (3-5 bar) with 5-10 cfm (141-283 l/min)
Water requirements	10-100 psi (0.7 - 6.9 bar) Backflow prevention is required – consult local plumbing ordinances for more information.
Liquid temperature range	40-100°F (4.4-37°C)
Chemical compatibility	Chemical products used with this equipment must be formulated for this type of application and compatible with unit materials and pump seals. For more information on chemical compatibility, consult the manufacturer or MSDS for your product or contact our customer service department.

SPECIFICATIONS	
	FI-WC-11AP2
Power type	Compressed air
Chemical pickup type	Draws from concentrated product
Dilution ratio range (water:chemical)*	1:1 to 16:1
Number of products unit can draw from	Two products, one at a time
Suction line length/diameter	8 ft. (2.4 m) clearbraided hose with 1/2 in. (12.7 mm) inside diameter (for each product)
Discharge hose diameter/length	50 ft. (15 m) hose, with 3/4 in. (19 mm) inside diameter
Discharge wand/tip type	32 in. (31.2 cm) polypropylene wand with zero tip and polypropylene ball valve
Output distance	15-20 ft. (4.6-6.1 m)
Output volume	20 gal/min (75 l/min) of foam
Flow rate*	1.6 gal/min (6 l/min)
Pump seals	Santoprene
Fluid fittings type	All-poly

*Dilution rates and flow rates given are based on chemical with viscosity of water and factory air pressure settings.

READ ALL INSTRUCTIONS BEFORE OPERATING EQUIPMENT

Installation Instructions:

1. Remove all components from packaging.
2. Select desired area to mount the control box.
Note: We recommend mounting the control box at a height of 6 feet or less. The chemical suction lines must reach the bottom of the chemical container. The bottom of the chemical container should not be positioned higher than the bottom of the control box.
3. Attach the control box mounting feet to the back of the control box, using the four screws provided in the parts package.
4. Mount the control box to the wall using four of the screws and plastic anchors provided in the parts package.
Note: To drill holes for the plastic anchors, use a 5/16 inch drill bit.
5. Mount the hose hanger in a convenient location using the remaining two screws and anchors provided in the parts package.
6. Attach the discharge hose assembly to the discharge hose barb (HB1234) and secure it with the larger hose clamp provided in the parts package.
7. Connect the air inlet hose barb (HBSS1438) provided in the parts package to the air inlet valve (BVB14) located on the side of the control box. Then attach a 3/8 inch I.D. air line from your air compressor to the air inlet hose barb, and secure it with the smaller hose clamp provided in the parts package.
8. Connect a water line to the water inlet fitting (SNB34GH).
Note: A back-flow preventer must be installed in the water line – check local plumbing codes to ensure proper installation.
9. Insert the proper metering tips and connect the chemical intake lines to the inlet barbs. Note: Use the included metering tip color charts to determine the appropriate metering tip based on the product and dilution rate you will be using.
10. Place the other end of each chemical intake line into a chemical container.

METERING TIP COLOR CHART		
Metering Tip Color	Diameter (Inches)	Ratios (Water:Chemical)**
NO TIP	NO TIP	1:1
GREY	0.128	1.5:1
BLACK	0.098	2.25:1
BEIGE	0.07	3.25:1
RED	0.052	4.25:1
WHITE	0.043	6.5:1
BLUE	0.04	7.5:1
TAN	0.035	9:1
GREEN	0.028	11:1
ORANGE	0.025	16:1
<i>BROWN*</i>	<i>0.023</i>	<i>22:1</i>
<i>YELLOW*</i>	<i>0.02</i>	<i>27:1</i>
<i>PURPLE*</i>	<i>0.014</i>	<i>43:1</i>
<i>PINK*</i>	<i>0.01</i>	<i>53:1</i>
<p>* Use of these metering tips is not recommended. At ratios greater than 16:1 (water:chemical), the output volume of the unit may be greatly reduced.</p> <p>** Injection rates will vary based on chemical viscosity, air pressure, and many other factors. We recommend testing unit output to verify injection rate prior to use.</p>		

READ ALL INSTRUCTIONS BEFORE OPERATING EQUIPMENT

Operation Instructions:

1. Slowly open the discharge valve (HV34) to begin foaming. The discharge valve should be completely open while foaming.
2. Adjust the needle valve (NV14Y), located inside the control box, to regulate the wetness or dryness of the foam following the steps below:
 - a. Close needle valve (NV14Y) completely in clockwise direction.
 - b. Open needle valve (NV14Y) in counter-clockwise direction 3 complete turns.
 - c. Continue to open needle valve in ¼ turn increments, allowing 30 seconds between adjustments, until desired consistency of foam is achieved.

After Use Instructions:

1. Place the chemical suction line into a container of water.
2. Open the discharge valve (HV34), and allow the unit to be flushed with water for approximately 2-4 minutes or until all chemical has been discharged from system.
3. Close air inlet valve (BVB14).
4. Shut off the water supply to the unit.
5. Open the discharge valve to relieve any pressure remaining in the unit.
6. Close the discharge valve after all pressure has been relieved from the unit. Store the unit with the discharge valve in the closed position.

Maintenance Instructions:

To keep your foam unit operating properly, periodically perform the following maintenance procedures:

Note: Before performing any maintenance, ensure that the unit has been disconnected from the air/water supply and depressurized according to the "After Use Instructions" above.

- Inspect the pump (P56) for wear and leaks.
- Inspect all hoses for leaks or excessive wear. Make sure all hose clamps are in good condition and properly secured.
- Replace the filter located within the air regulator (R25) as needed. Clean by unthreading the air regulator bowl from the air regulator (R25).
- Check the chemical metering tips, intake lines and strainers for debris and clean as needed.
- Drain the air compressor tank on a regular basis to help extend pump life. An air source with a high moisture content will accelerate pump wear. Note: If the air source has a high moisture content, you may wish to install a water separator (WS-20CFM) before the unit.

Troubleshooting Instructions:

- Check to ensure that the discharge hose is uncoiled properly, and that there are no kinks that could obstruct fluid flow.
- Check the air regulator bowl and air filter for debris such as water, oil, or rust particles. Clean by unthreading the air regulator bowl from the air regulator (R25).
- If air passes through the pump (P56) without cycling, the pump needs to be replaced.
- If solution backs up into the air regulator bowl, the check valve (CV38-AP) needs to be replaced.
- Check for proper air pressure on the air gauge (AG100). The air regulator (R25) is factory set at 50 psi (3.4 bar). Operating range is 40 to 80 psi (3 to 5 bar) with 5 to 10 CFM (141.6 to 283.3 l/min).
- If the unit operates at a reduced pressure:
 - o Check the air compressor supplying the unit. If the pressure is less than 40 psi (3 bar), turn the unit off until the compressor can catch up.
 - o If the air supply is 50 psi (3.4 bar) or above, check the air gauge (AG100), which should read near 50 psi (3.4 bar). If the air gauge reads more or less than 50 psi (3.4 bar), adjust the pressure by turning the knob on the top of the air regulator (R25).
- Check the chemical metering tips, intake lines and strainers for debris or damage. Clean or replace as needed. To prevent damage to the unit, strainers must always be used.
- Make sure proper foaming chemical and concentration are being used.
- If the needle valve (NV14Y) is open too far, the pump (P56/P56K/P56V) may cycle improperly due to lack of air pressure. If this occurs, close and readjust the needle valve (NV14Y) as described in Operation Instruction.
- If foam comes out wet, no matter where the needle valve (NV14Y) is positioned, the check valve (CV38-AP) may need to be replaced.
- Check for proper water pressure on the water pressure gauge (WRG14). To check the pressure:
 - o With the unit running, open the discharge valve (HV60/HV34) and allow the unit to run for about 1 minute.
 - o Close the discharge valve (HV60/HV34).
 - o Check the water pressure gauge (WRG14). The pressure should read 20 psi (1.4 bar).
 - o If necessary, adjust the water regulator using the flathead screw on the regulator body. The water pressure should be set at 20 psi (1.4 bar). Setting the pressure higher or lower may damage the unit or cause it to malfunction.

READ ALL INSTRUCTIONS BEFORE OPERATING EQUIPMENT

PARTS DIAGRAMS - UNITS WITH STANDARD FITTINGS

CONTROL BOX ASSEMBLY FRONT INSIDE VIEW

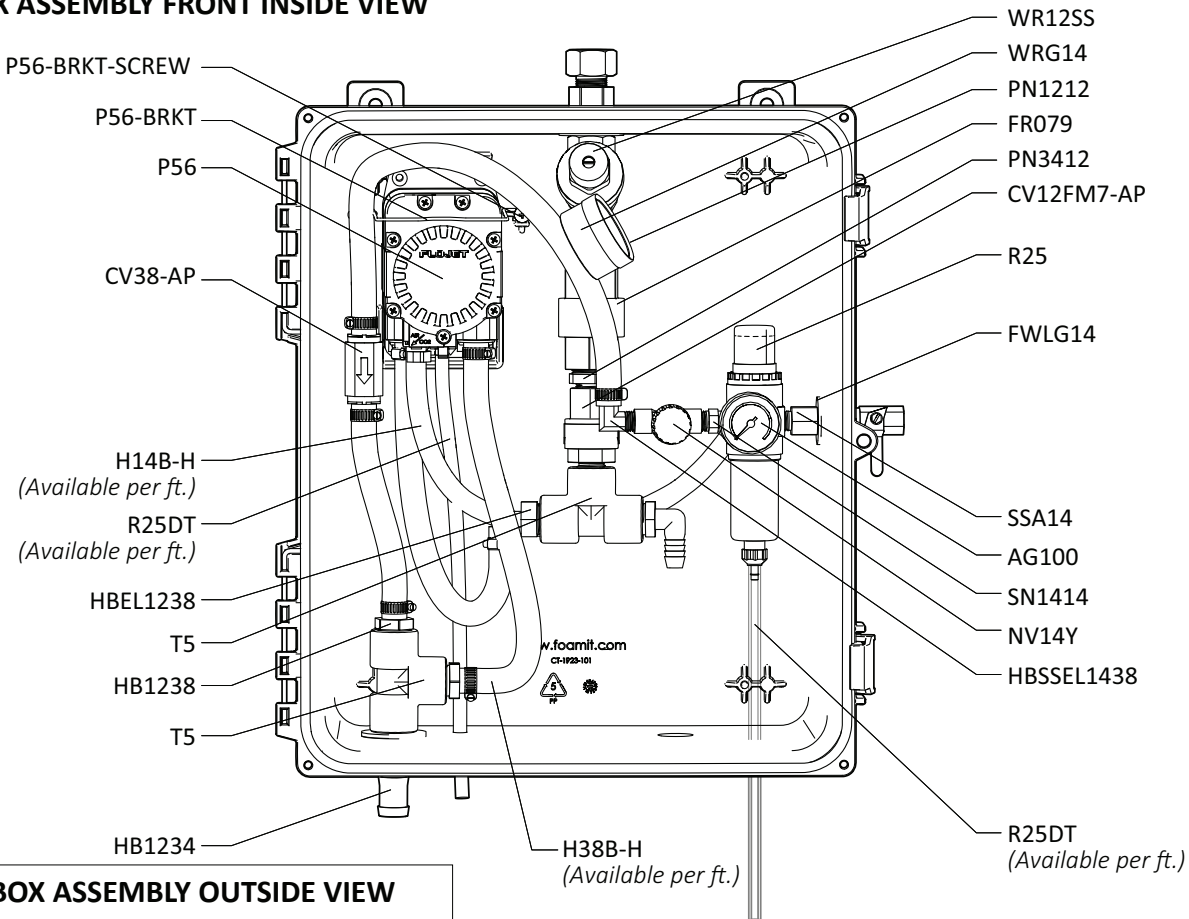

CONTROL BOX ASSEMBLY OUTSIDE VIEW

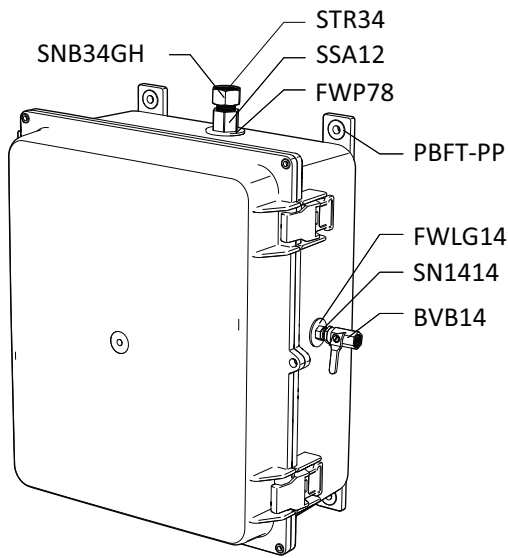

READ ALL INSTRUCTIONS BEFORE OPERATING EQUIPMENT

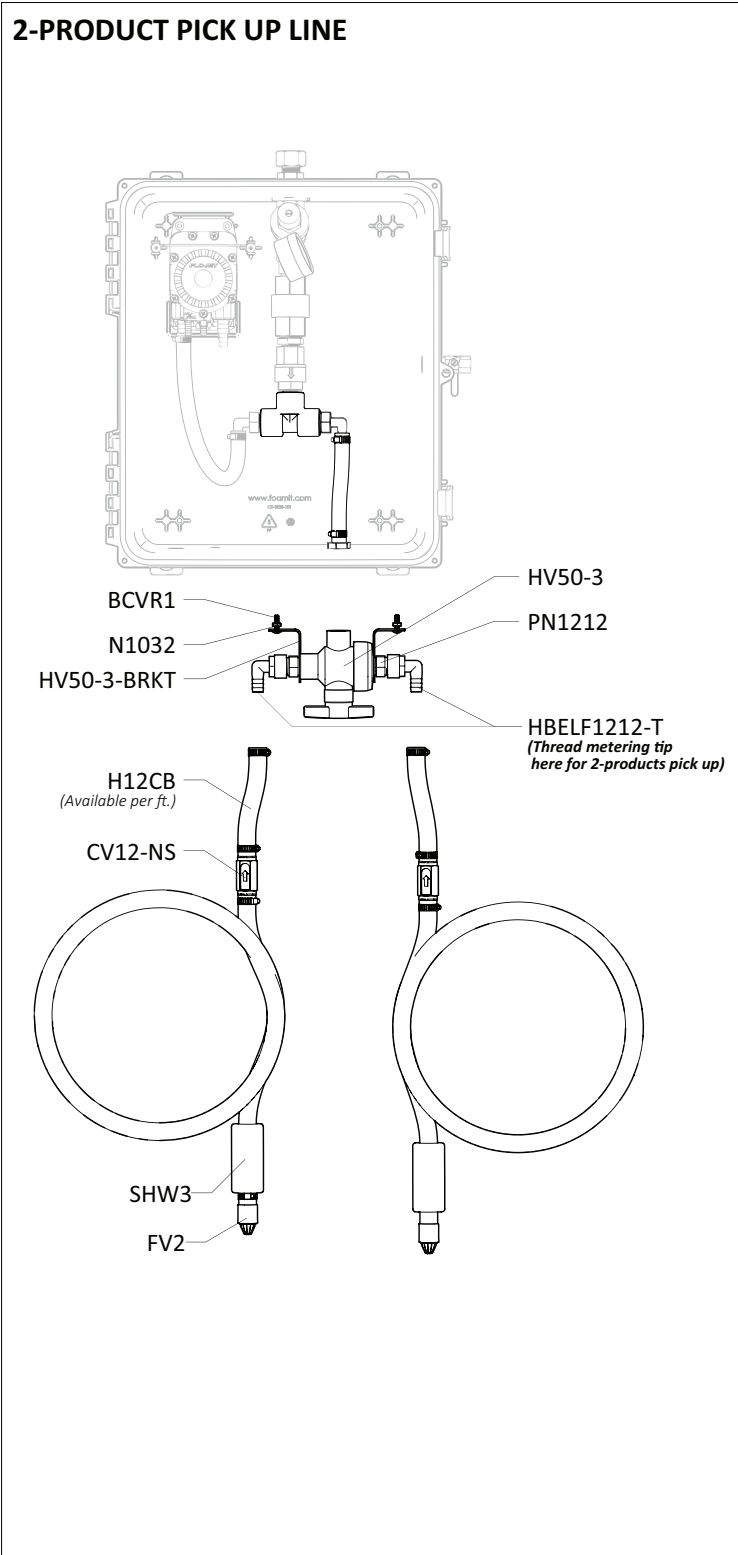

READ ALL INSTRUCTIONS BEFORE OPERATING EQUIPMENT

PARTS DIAGRAMS

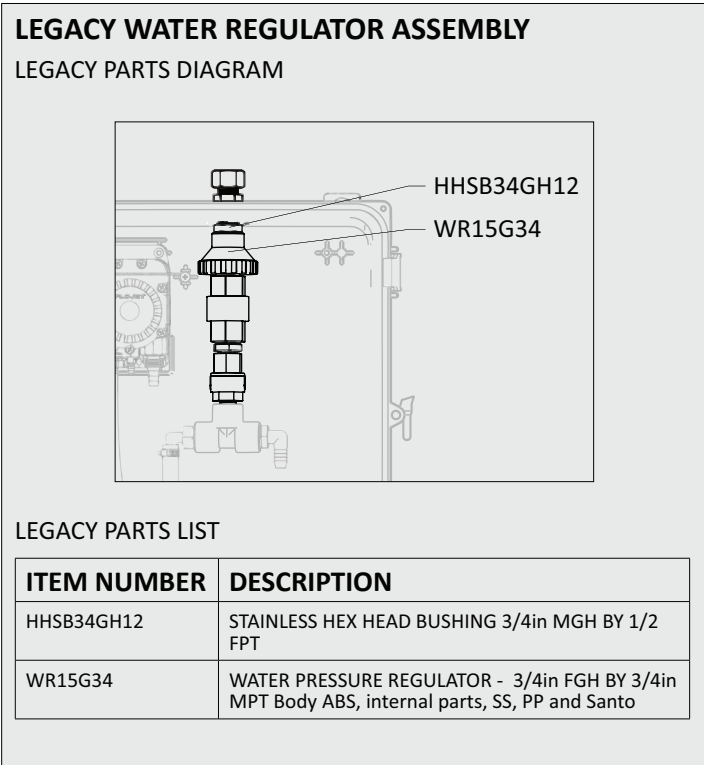
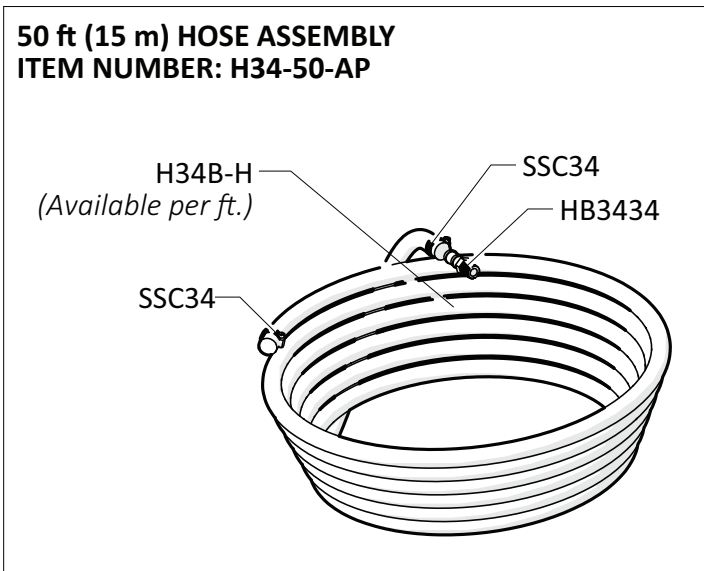
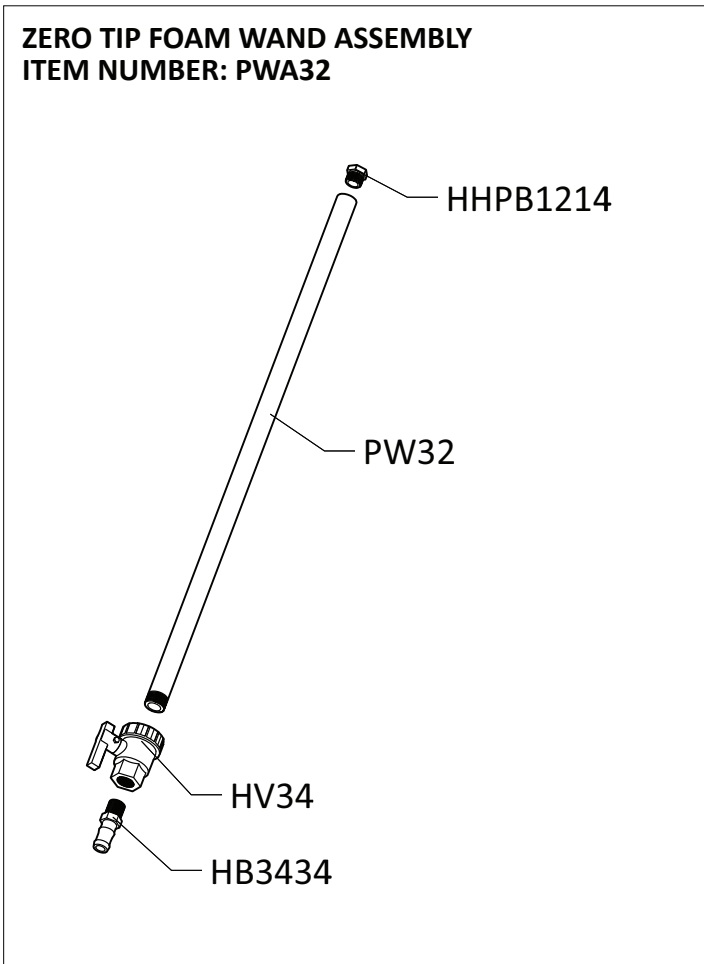

READ ALL INSTRUCTIONS BEFORE OPERATING EQUIPMENT

ITEM NUMBER	DESCRIPTION
AG100	1.5 INCH DRY MODEL 20 DUAL SCALE GAUGE
AKSS34-P	SS ANTI-KINK SPRING FOR 3/4 INCH HOSE
AKSS-HPC	ANTI-KINK STAINLESS STEEL HITCH PIN CLIP
BCVR1	10-32 X 1/2 PHIL PAN HEAD SS
BVB14	AIR INLET VALVE - VA BRS 025-4F4F-BT, NICKEL
CV12FM7-AP	WHITE 1/2 INCH FEMALE NPT INLET – BLACK 1/2 INCH MALE NPT OUTLET – EP SLEAS 7 PSI HASTELLOY SPRING
CV12-NS	1/2in BARB X 1/2in BARB PVC CHECK VALVE - NO SPRING - TEFLON BALL
CV38-AP	WHITE PVC CHECK VALVE 3/8 BARBS - HASTELLOY SPRING - TEFLON BALL
EC14-2	OETIKER CLAMP 13.8
FR079	687 SERIES FLOW RESTRICTOR - 0.79 GPM -- FP FR 687-12F12F-E.79 GPM
FV2	FOOT VALVE, VITON, BLUE
FWLG14	.569 ID X 1.28 OD X .08 THICK FLAT WASHER SS 18-8
FWP12	7/8 ID X 1.5 OD X 0.05 THK SSFW
FWP78	7/8in BY .137 BY 1 1/4in FLATWASHER 18-8 PLN
H12CB	1/2 IN (ID) CLEARBRAID RF SERIES
H14B-H	1/4 INCH BLUE HOSE- GOODYEAR HORIZON - Available per ft.
H34B-H	3/4 INCH BLUE GOODYEAR HORIZON HOSE - Available per ft.
H38B-H	3/8 INCH BLUE GOODYEAR HORIZON HOSE - Available per ft.
HB1234	1/2in MPT X 3/4in HOSE BARB
HB1238	1/2in MPT X 3/8in HOSE BARB
HB3434	POLY HOSE BARB 3/4in X 3/4in
HBEL1212-T	HOSE BARB ELBOW 1/2in MPT X 1/2in BARB - TAPPED FOR METERING TIP
HBEL1238	HOSE BARB ELBOW 1/2 X 3/8
HBELF1212-T	HOSE BARB ELBOW 1/2in BY FPT 1/2in - TAPPED FOR METERING TIP
HBSS1438	STAINLESS HOSE BARB 1/4 MPT X 3/8 BARB
HBSSSEL1438	STAINLESS HOSE BARB ELBOW 1/4 INCH NPT X 3/8 HOSE BARB
HBSSSEL1814	304 STAINLESS ELBOW 1/8 INCH NPT X 1/4 INCH HOSE BARB
HHPB1214	HEX HEAD POLY REDUCER BUSHING 1/2in X 1/4in
HHSB34GH12	STAINLESS HEX HEAD BUSHING 3/4in MGH BY 1/2 FPT
HV34	3/4in POLY BALL VALVE
HV50-3	3-WAY BALL VALVE - 1/2 INCH - FIBER GLASS RE-ENFORCED POLYPROPELENE BODY - TEFLON SEATS - EPDM O-RING
HV50-3-BRKT	SS BRACKET FOR HV50-3
MTK 511	METERING TIP KIT - 511/530
N1032	10-32 HEX MACH SCREW NUT 18-8
NV14Y	FLOW CONTROL VALVE - INCLUDES BLACK KNOB
NV14Y-HNDL	KNOB FOR 2839-1/4 NEEDLE VALVE
P56	5700 PUMP WITH SANTOPRENE SEALS - INCLUDES HOSE BARBS, AIR FITTING, AND AIR PORT
P56K	5700 PUMP WITH KALREZ SEALS - INCLUDES HOSE BARBS, AIR FITTING, AND AIR PORT

ITEM NUMBER	DESCRIPTION
P56V	5700 PUMP WITH VITON SEALS - INCLUDES HOSE BARBS, AIR FITTING, AND AIR PORT
20756103B	Polypro G57 Air Port x HB Straight, w/ Viton o-ring
HB14P	1/4in BRASS HB AIR FITTING /G57/P56
HB5638	HOSE BARB FOR P56 PUMP
HB5638K	HOSE BARB FOR P56K PUMP
HB5638V	HOSE BARB FOR P56V PUMP
P56-BRKT	PUMP BRACKET- STAINLESS STEEL
P56-BRKT-SCREW	HI LO SCREW FOR RETAINING P56-BRKT
PB16138	POLYPROPYLENE CONTROL BOX - WORKING DIMS 16x13x8 - PUMP MOUNT
PB16138-GSKT	NEOPRENE GASKET 0.220 INCH ROUND CORD STOCK - 61.125 INCHES
PB16138-LATCH	LATCH FOR PB16138
PB16138-PIN	STAINLESS STEEL HINGE PIN FOR CONTROL BOX PB16138 - 1/8 x 4 3/4 x 1/2inches
PBFT-PP	MOUNTING FEET FOR POLYBOX - PB16138 - POLYPROPYLENE
PL16138	CONTROL BOX LID - POLYPROPYLENE - 16x13x8 - HINGED LOCKABLE LID
PN1212	1/2in MPT X 1/2in MPT POLY NIPPLE
PN3412	3/4in MPT X 1/2in MPT POLY NIPPLE
PW32	3/4in BLACK POLY PRO X 32in - FPTOE & MPTOE - SCH.80
R25	AIR REGULATOR - 1/4ft TWO PORT 1/8ft TWO PORT - INCLUDES FILTER AND BOWL
AFR25	AIR FILTER for R25
ABR25	METAL AIR BOWL for R25
R25DT	3/16 X 5/16 CLEAR PVC TUBING - Available per ft.
S1034FHL	10 X 3/4 PHIL FLAT HI-LO THRD SCREW 18-8
SA12B	GARDEN HOSE SWIVEL ADAPTER X 1/2 MPT
SHW3	3in LONG COATED WEIGHT
SN1414	STAINLESS 1/4MPT X 1/4MPT NIPPLE
SNB34GH	BRASS 3/4 GH SWIVEL NUT
SSA12	STAINLESS MALE/FEMALE S.S. ADAPTOR 1/2in X 1/2in
SSA14	SS304 MALE/FEMALE ADAPTOR 1/4 NPT X 1/4 NPT
SSC12	WORM GEAR CLAMP, S/S (.31-.91)
SSC34	WORM GEAR CLAMP, S/S (.75-1.25)
SSC38	WORM GEAR CLAMP, S/S (.25-.63)
SSHH-F	S.S. LASER CUT HOSE HANGER - FLAT STOCK
STR34	1in SEAL/STRAINER FOR 3/4 GH FITTINGS
T5	1/2 POLY TEE
WMS14	14 X 1 1/4 HEX W/H SMS SLOTT, S/S
WMS14A	5/16 X 1 1/2 STRAIGHT PLASTIC ANCHOR
WR12SS	WATER PRESSURE REGULATOR - STAINLESS STEEL - 1/2 INCH FPT
WR15G34	WATER PRESSURE REGULATOR - 3/4in FGH BY 3/4in MPT Body ABS, internal parts, SS, PP and Santo
WRG14	WATER PRESSURE REGULATOR GAUGE FOR WR12SS
WS-20CFM	TSUNAMI WATER SEPARATOR 20 CFM

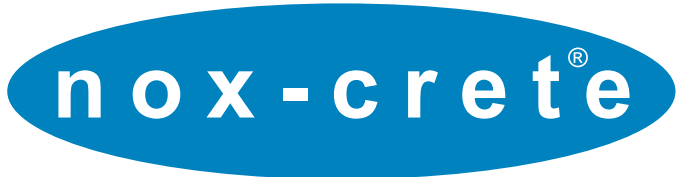

chemical solutions to concrete problems



Nox-Crete, Inc.
1444 S. 20th St. • Omaha, NE 68108
402-341-2080 • www.nox-crete.com